

VALVES FOR HYDRAULIC MOTORS

CONTENTS

- Valves for MLHP, MLHR and MLHH type KPBR ... 35
- Valves for MLHS type KPBS 36
- Valves for MLHT type KPBT 37
- Valves for MLHV type KPBV 38
- Valves for MLHRW and HW type KPBW 39
- Valves for HP and HR type KPBHR...E 40
- Valves for HP and HR type KPBHR...D 41
- Switch valves type KPWR and KPWS 42
- Switch valves type KPWT and KPWW 43

- Crossover Relief Valves 44
- Valves for MLHP, MLHR and MLHH type KP...R ... 45
- Valves for MLHS type KP...S 45
- Valves for MLHT type KP...T 46
- Valves for MLHV type KP...V 48
- Valves for MLHRW and HW type KP...W ... 51
- Cross Port Relief Valves 52
- Order Code 53

OVERCENTER VALVES WITH BRAKE CONTROL

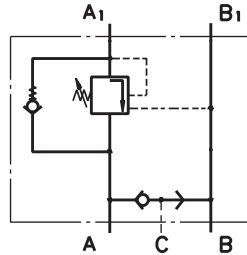

Single Overcenter Valves with Brake Control type KPBR ... AE

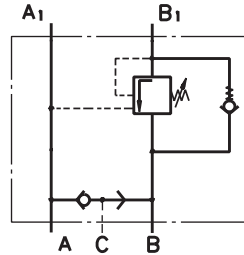

Single Overcenter Valves with Brake Control type KPBR ... BE

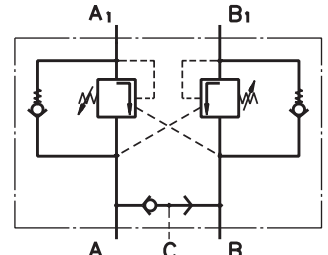

Dual Overcenter Valves with Brake Control type KPBR ... D

SPECIFICATION DATA

Parameters	Type											
	KPBR...E	KPBS...E	KPBR...D	KPBS...D	KPBW...E	KPBW...D	KPBHR...E	KPBHR...D	KPBT...E	KPBT...D	KPBV...E	KPBV...D
Flow Rate, GPM [lpm]	15.85 [60]						26.4 [100]		52.8 [200]			
Rated PSI Pressure*, [bar]	870÷4060 [60÷280]						1015÷3625 [70÷250]					
Pilot Ratio	4,25:1											
Weight, lb [kg]	6.658 [3,020]	6.39 [2,900]	6.746 [3,060]	6.437 [2,920]	7.724 [3,050]	6.923 [3,140]	5.071 [2,300]	5.291 [2,400]	11.905 [5,400]	12.787 [5,800]	20.283 [9,200]	21.495 [9,750]

*Pressure Settings are at flow rate of 1.3 GPM [5 lpm] and viscosity 150 SUS [32 mm²/s] at 122° F [50 °C].

PRESSURE LOSSES

KPBR..., KPBS..., KPBW... and KPBHR...

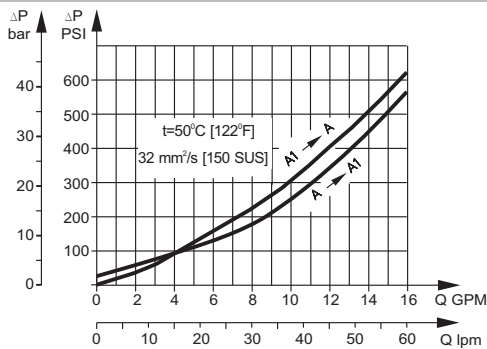

KPBT...

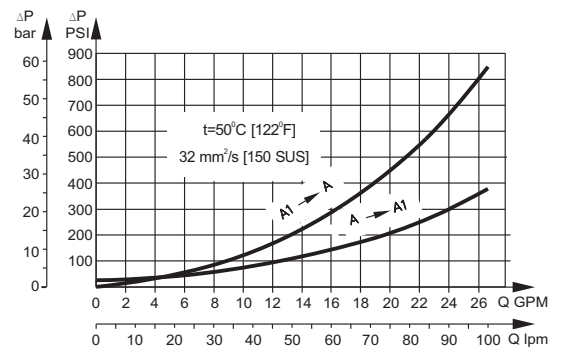

KPBV...

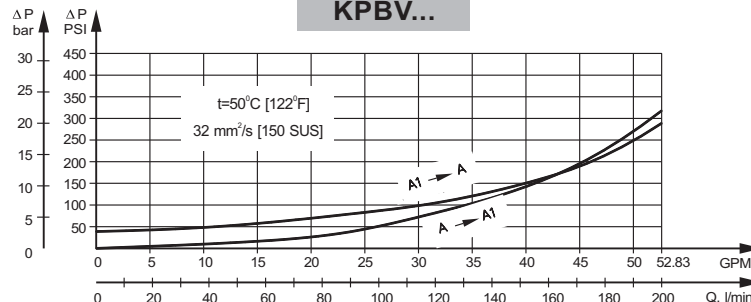

VALVES FOR MLHP, MLHR, MLHH HYDRAULIC MOTORS

SINGLE VALVE KPBR-250/1/E...

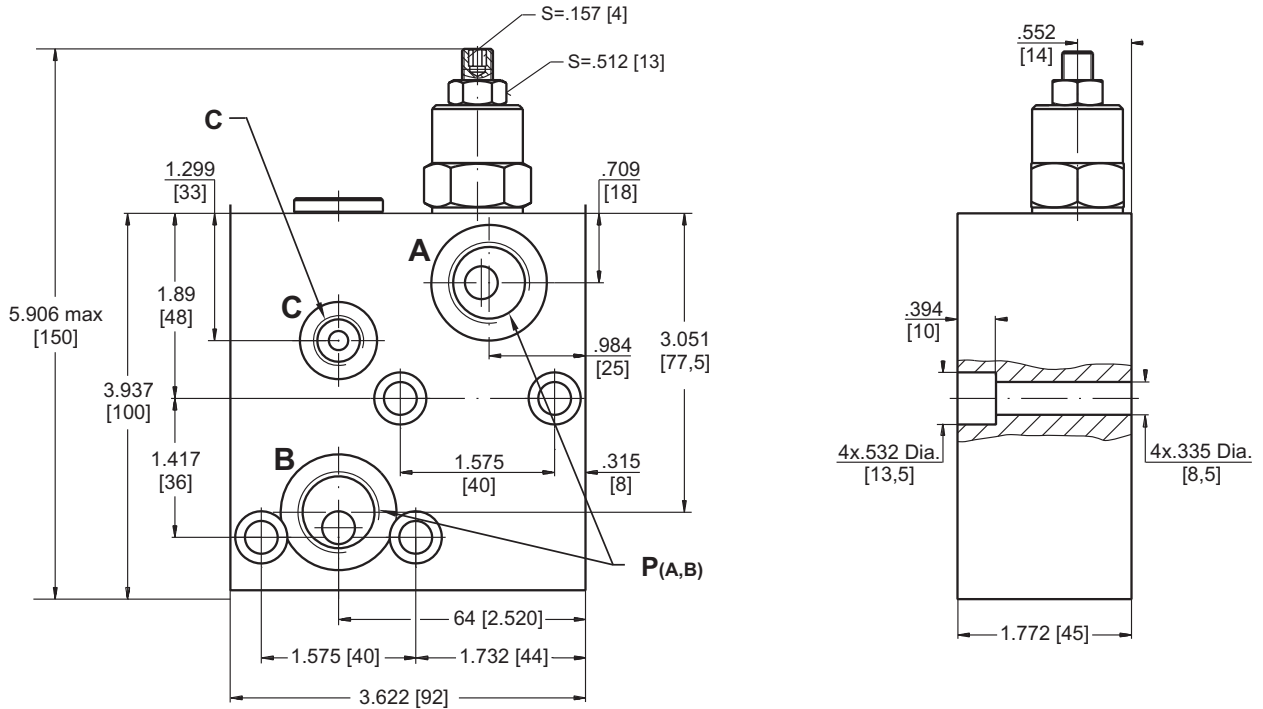

DUAL VALVE KPBR-250/1/D...

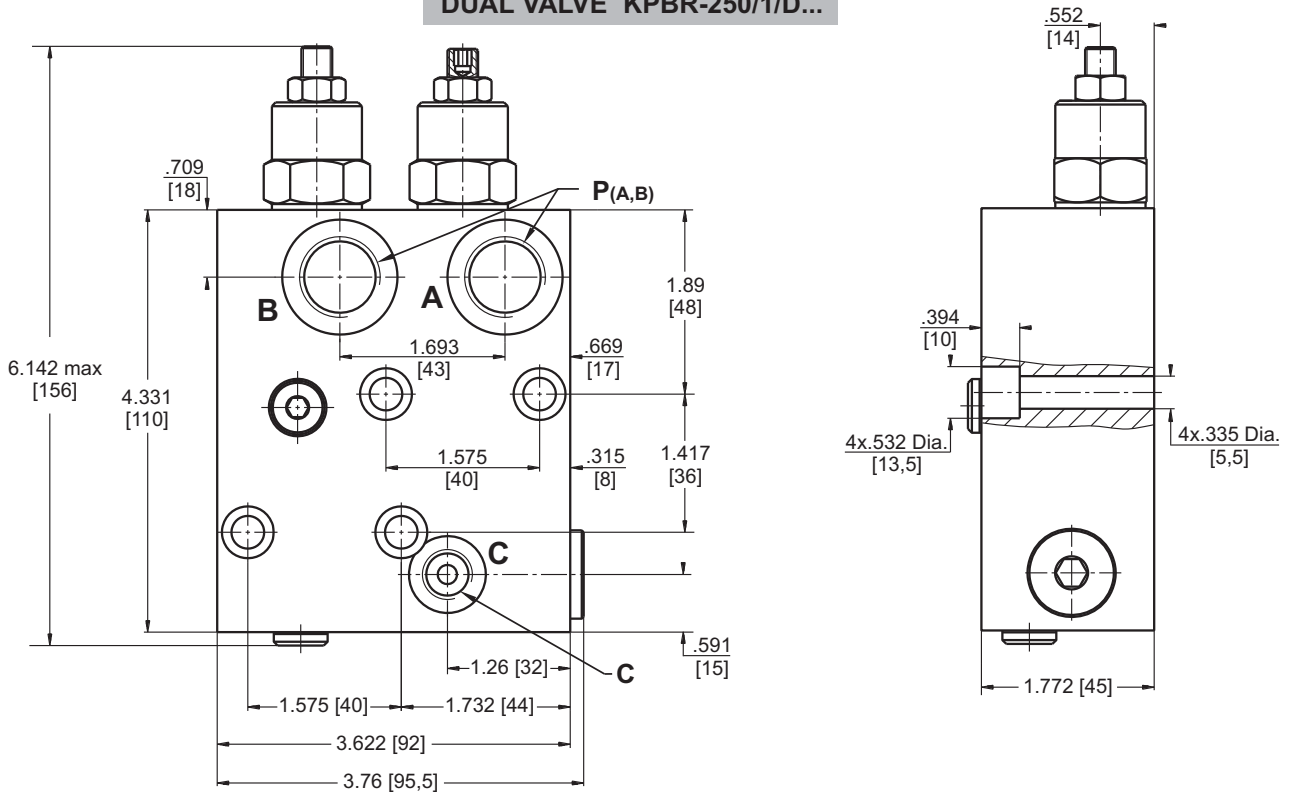

	Thread Ports - P _(A,B)	Thread Port - C
-	G1/2 .63 [16] depth	G1/4 .47 [12] depth
M	M22x1,5 .63 [16] depth	M14x1,5 .47 [12] depth
A	7/8 - 14 UNF O-ring .63 [16] depth	7/16 - 20 UNF O-ring .50 [12,7] depth



Note : KPBR Blocks are installed directly on MLHP, MLHR and MLHH Motors with four screws 5/16-18UNC, 1.75 long ANSI B 18.3 or M8x45 - 8.8 DIN 912. Tightening torque 168÷150 lb-in [1,7^{+0,2} daNm].

VALVES FOR MLHS HYDRAULIC MOTORS

SINGLE VALVE KPBS-250/1/E...

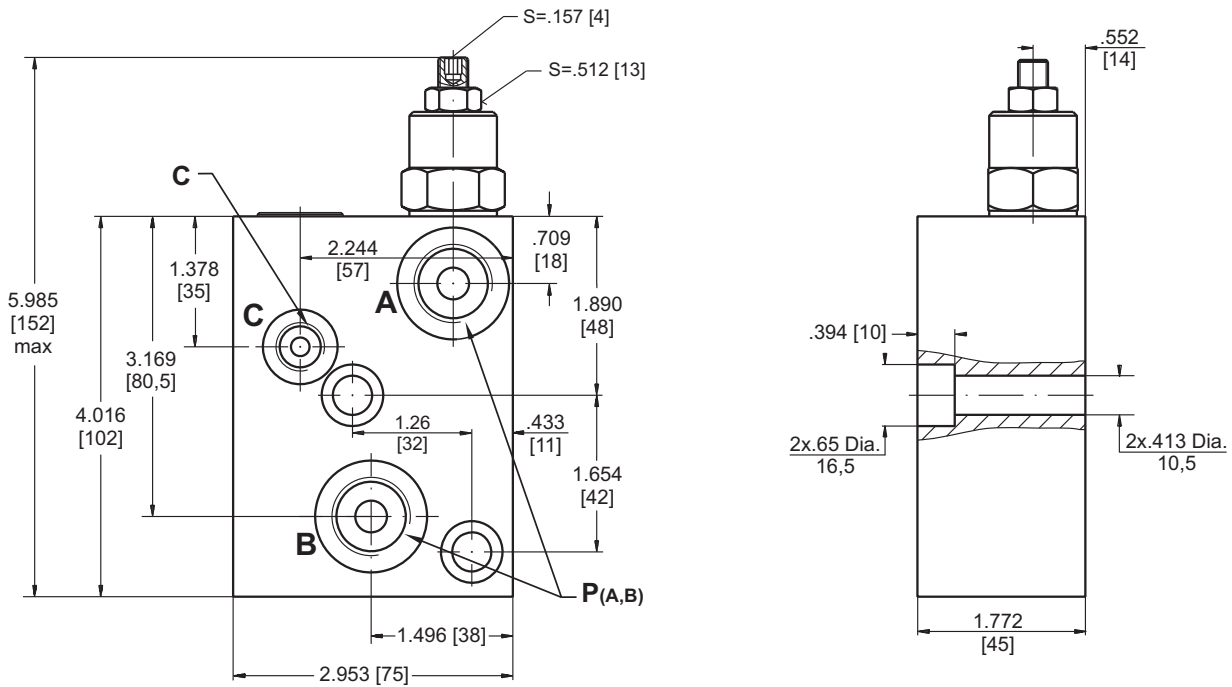

DUAL VALVE KPBS-250/1/D...

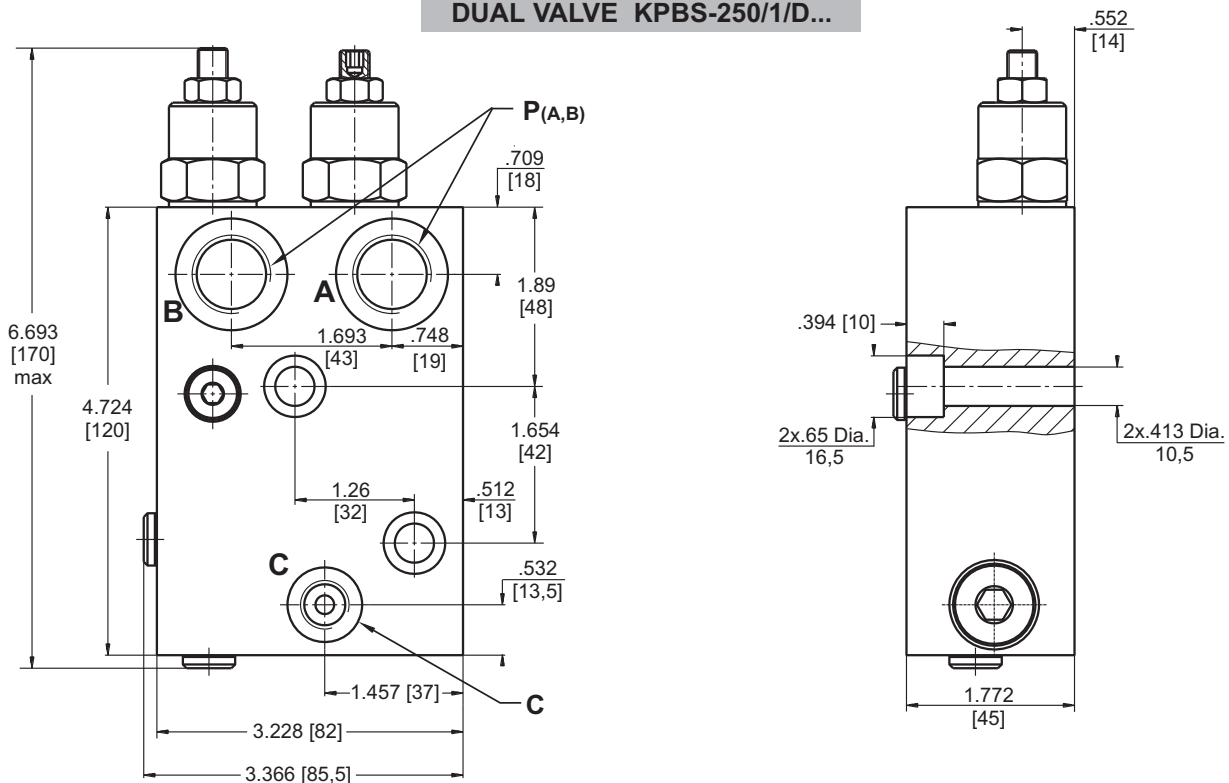

	Thread Ports - P _(A,B)	Thread Port - C
-	G1/2 .63 [16] depth	G1/4 .47 [12] depth
M	M22x1,5 .63 [16] depth	M14x1,5 .47 [12] depth
A	7/8 - 14 UNF O-ring .63 [16] depth	7/16 - 20 UNF O-ring .50 [12,7] depth



Note : KPBS Blocks are installed directly on MLHS Motors with two screws 3/8-16UNC, 1.75 long ANSI B 18.3 or M10x45 - 8.8 DIN 912. Tightening torque 336÷310 in-lb [3,5^{+0,3} daNm].

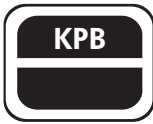

VALVES FOR MLHT HYDRAULIC MOTORS

SINGLE VALVE KPBT-250/1/E...

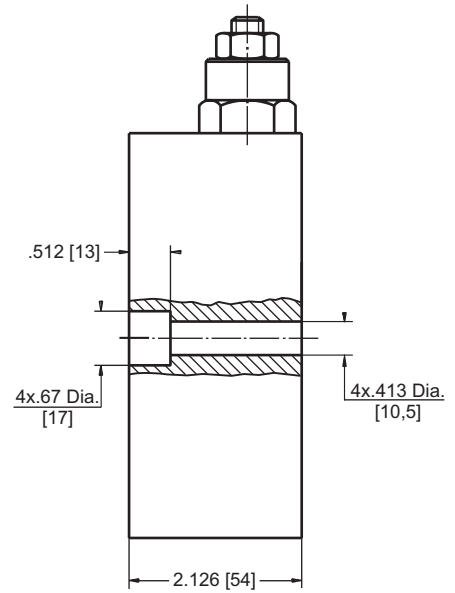
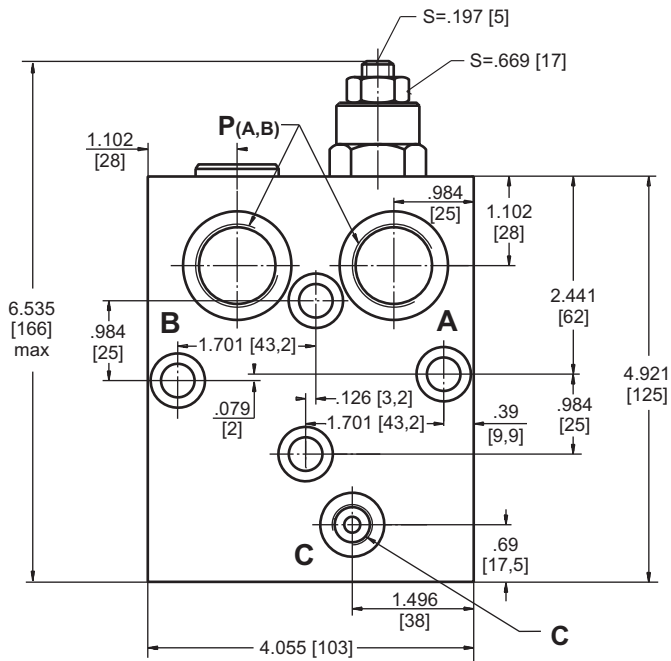

DUAL VALVE KPBT-250/1/D...

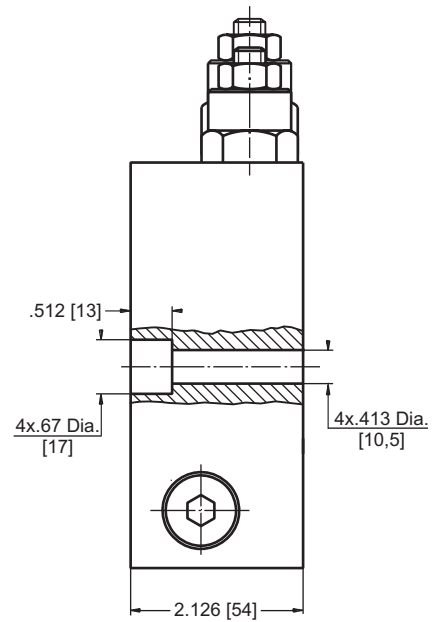
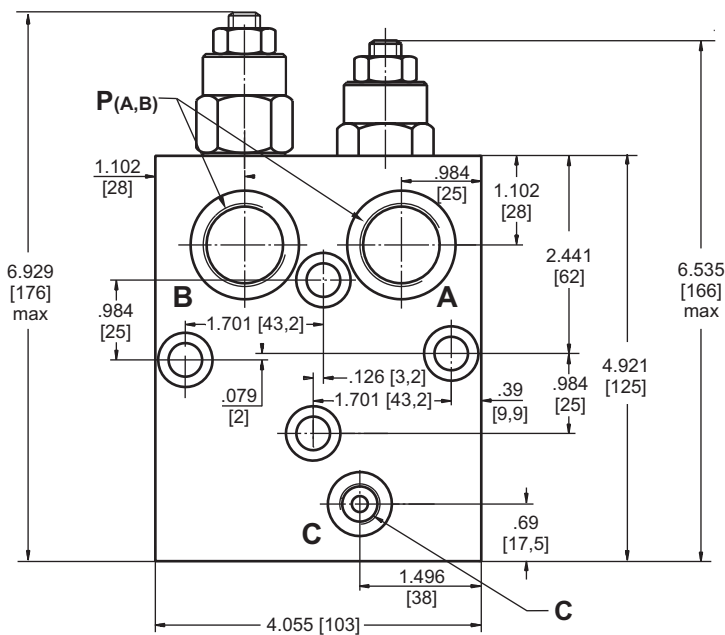

	Thread Ports - P _(A,B)	Thread Port - C
-	G3/4 .67 [17] depth	G1/4 .55 [14] depth
M	M27x2 .67 [17] depth	M14x1,5 .55 [14] depth
A	1 1/16-12 UN O-ring .67 [17] depth	7/16 - 20 UNF O-ring .50 [12,7] depth



Note : KPBT Blocks are installed directly on MLHT Motors with four screws M10x50 - 8.8 DIN 912. Tightening torque 336±310 lb-in [3,5^{+0,3} daNm].

VALVES FOR MLHV HYDRAULIC MOTORS

DUAL VALVE KPBV-250/1/D...

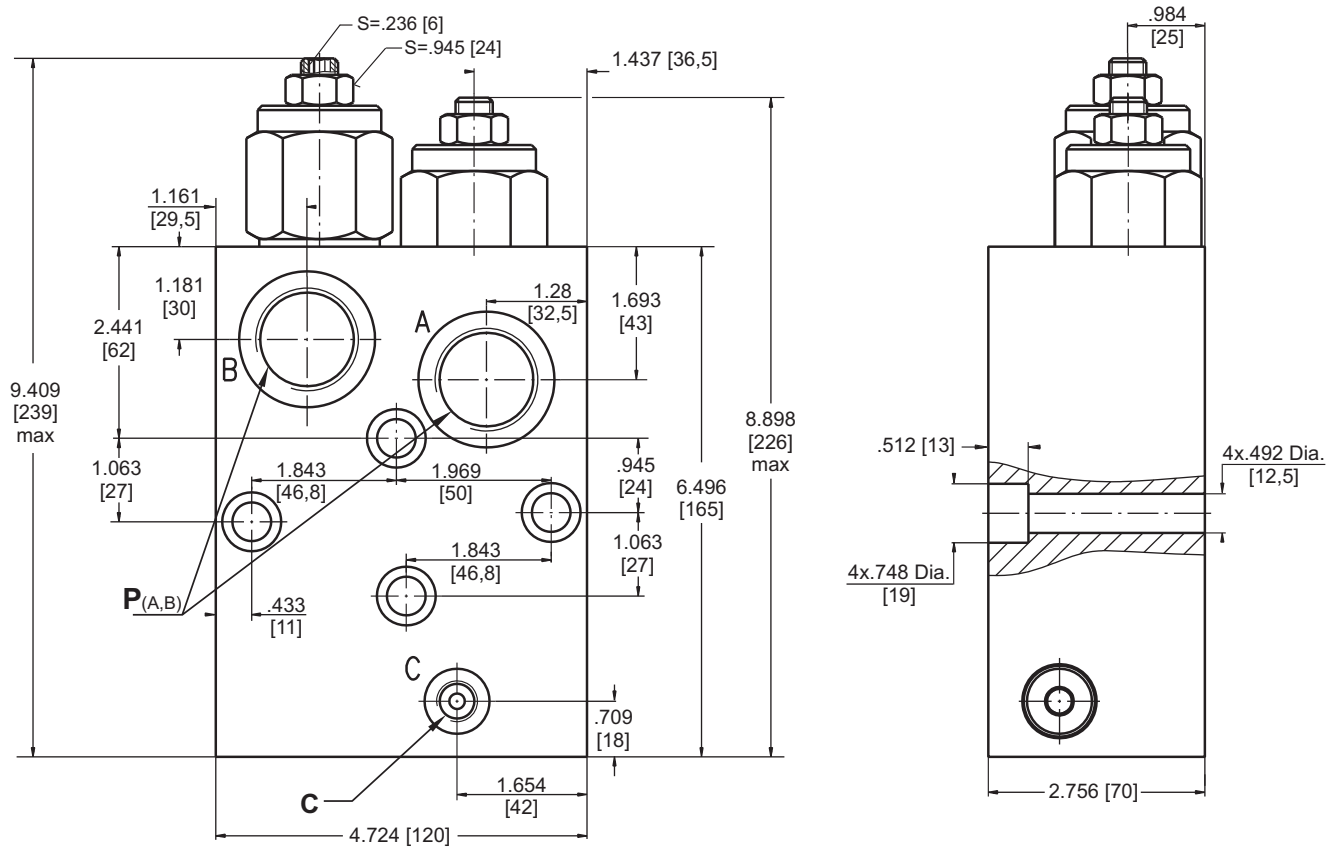

SINGLE VALVE KPBV-250/1/AE...

SINGLE VALVE KPBV-250/1/BE...

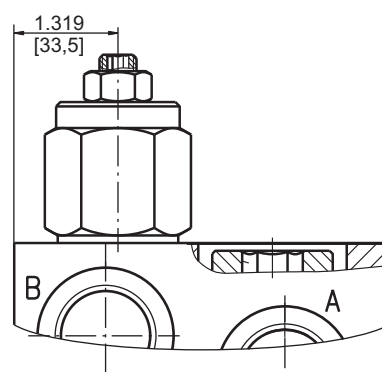
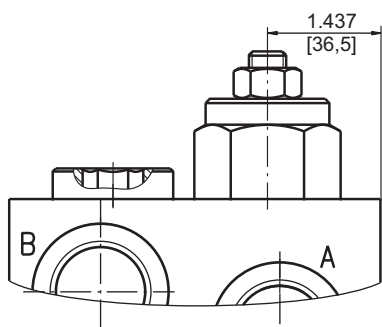

	Thread Ports - P _(A,B)	Thread Port - C
-	G 1 .79 [20] depth	G1/4 .55 [14] depth
M	M33x2 .79 [20] depth	M14x1,5 .55 [14] depth
A	1 5/16 - 12 UN O-ring .79 [20] depth	7/16 - 20 UNF O-ring .5 [12,7] depth



Note : KPBV Blocks are installed directly on MLHV Motors with four screws M12x70 - 8.8 DIN 912. Tightening torque 620+575 lb-in [6,5^{+0,5} daNm].

VALVES FOR MLHRW and HW HYDRAULIC MOTORS

DUAL VALVE KPBW-250/1/D...

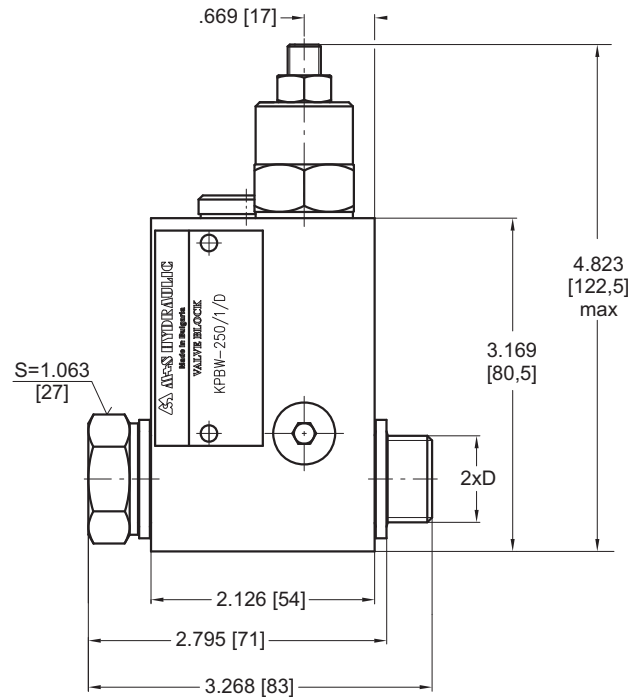
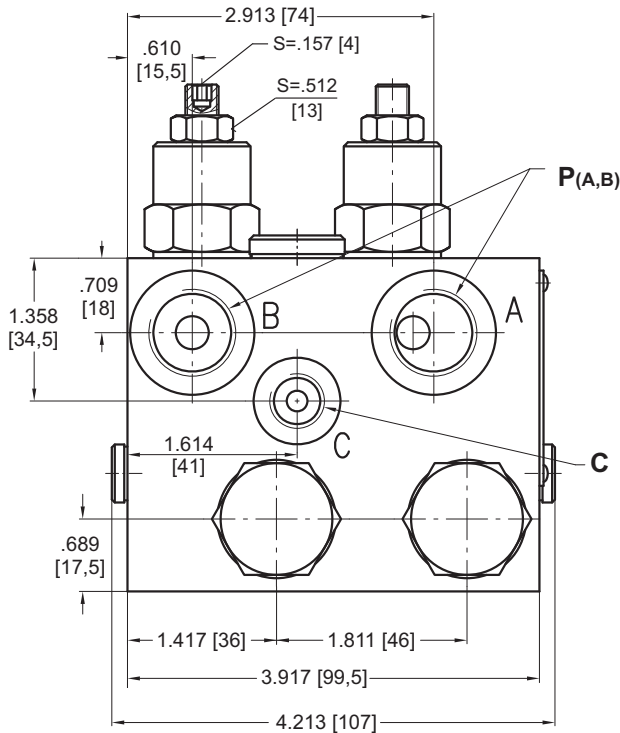

KPBW-...A

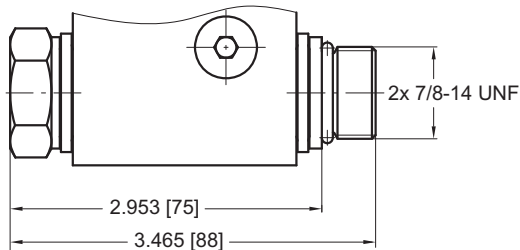

SINGLE VALVE KPBW-250/1/AE...

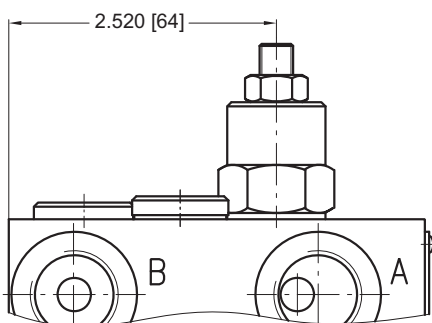

SINGLE VALVE KPBW-250/1/BE...

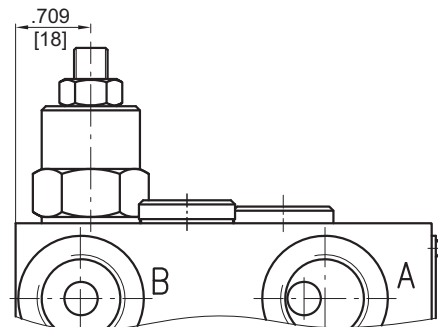

	Thread Ports - P _(A,B)	Thread Port - C	Thread Ports - D
-	G1/2 .63 [16] depth	G1/4 .47 [12] depth	G1/2 .47 [12] length
M	M22x1,5 .63 [16] depth	M14x1,5 .47 [12] depth	M22x1,5 .47 [12] length
A	7/8 - 14 UNF O-ring .63 [16] depth	7/16 - 20 UNF O-ring .50 [12,7] depth	7/8 - 14 UNF O-ring .51 [13] length



Note : KPBW Blocks assembly to MLHRW or HW motors is done with two screws (thread D) included in the valve set. Tightening torque 710 lb-in [8 daNm].

VALVES FOR HP, HR HYDRAULIC MOTORS

SINGLE VALVE KPBHR-250/1/BE...

SINGLE VALVE KPBHR-250/1/AE...

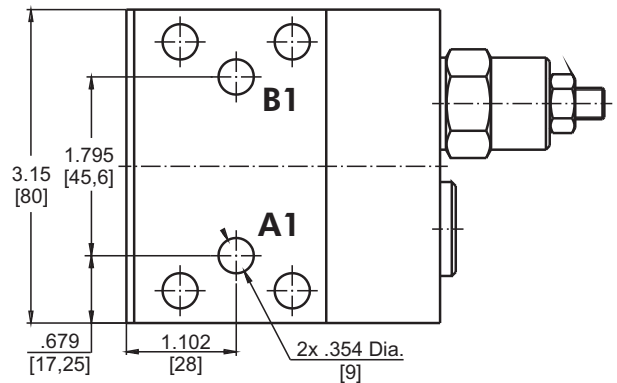
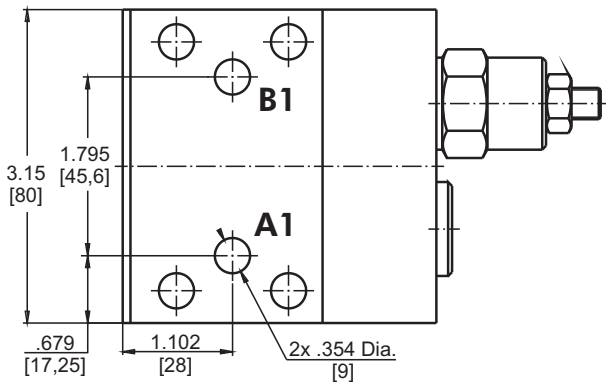
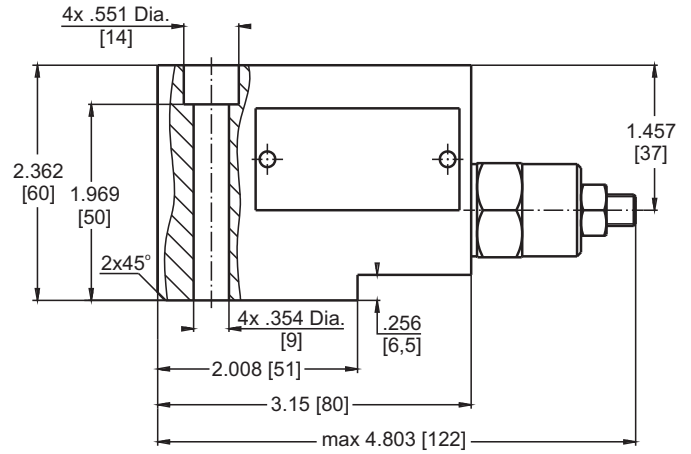
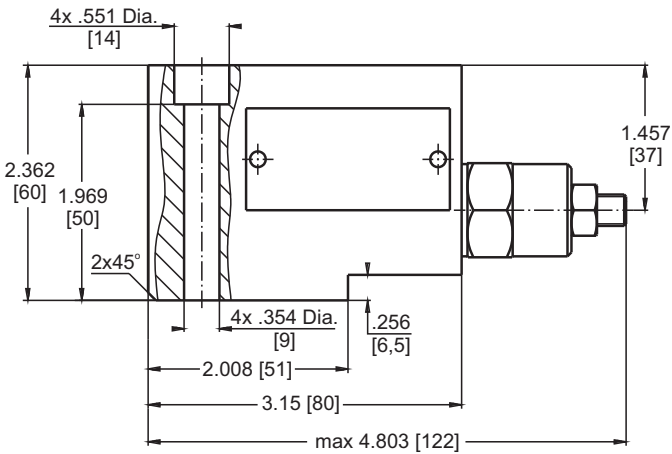
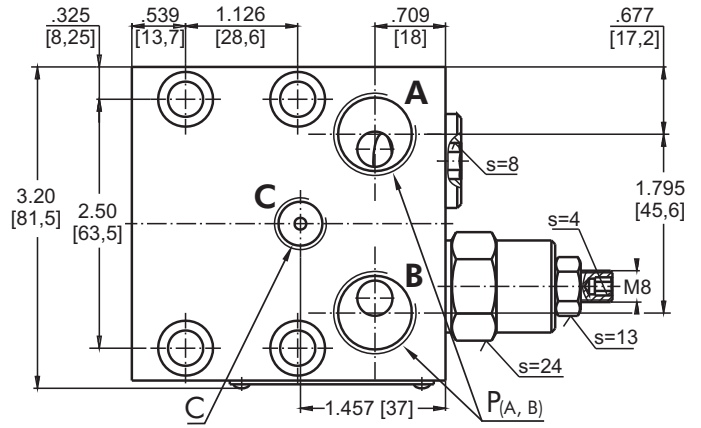
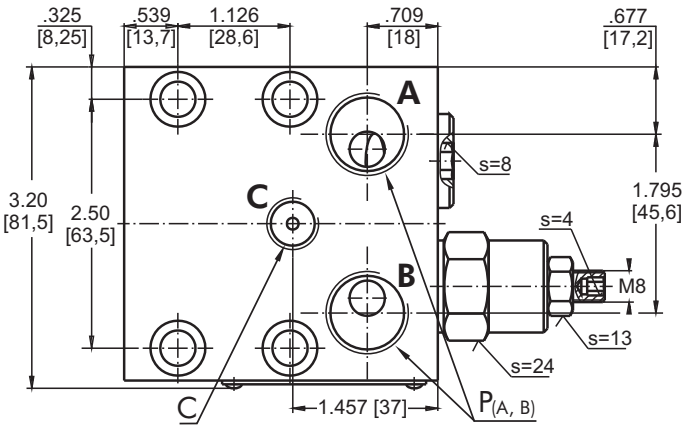

	Thread Ports - P _(A,B)	Thread Ports - C
A	7/8 - 14 UNF O-ring .67 [17] deep	7/16 - 20 UNF O-ring .50 [12,7] deep
-	G1/2 .67 [17] deep	G1/4 .55 [14] deep
M	M22x1,5 .67 [17] deep	M14x1,5 .55 [14] deep

Note : KPBHR Blocks are installed directly on HP and HR Motors with four bolts 5/16-18UNC, 2.36 long or M8x60 - 8.8 DIN 912. Tightening torque 265±221 lb-in [2,5^{+0,5} daNm].

VALVES FOR HP, HR HYDRAULIC MOTORS

DUAL VALVE KPBHR-250/1/D...

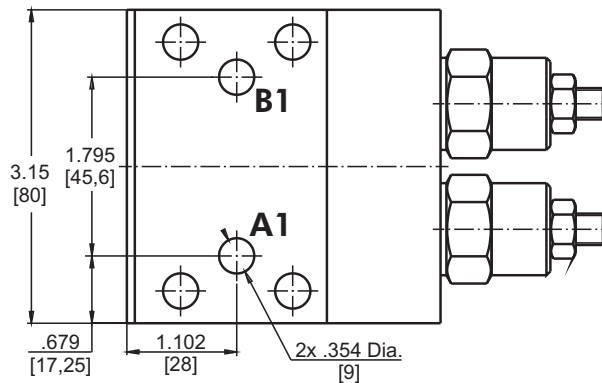
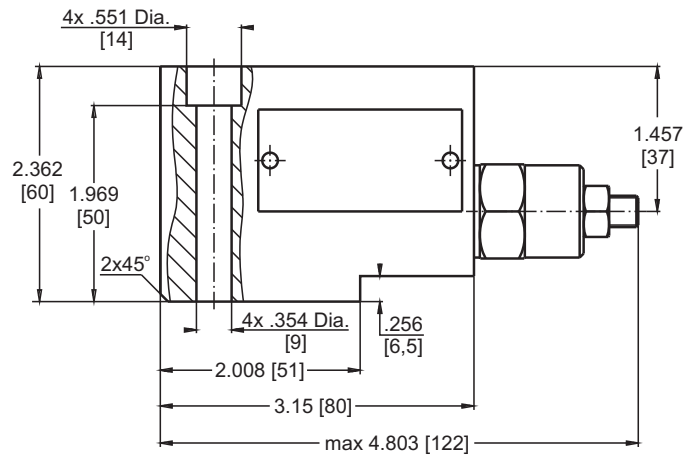
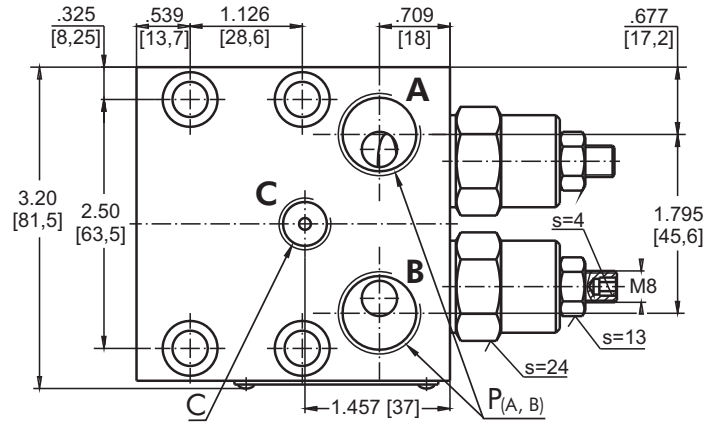

	Thread Ports - P _(A,B)	Thread Ports - C
A	7/8 - 14 UNF O-ring .67 [17] deep	7/16 - 20 UNF O-ring .50 [12,7] deep
-	G1/2 .67 [17] deep	G1/4 .55 [14] deep
M	M22x1,5 .67 [17] deep	M14x1,5 .55 [14] deep

Note : KPBHR Blocks are installed directly on HP and HR Motors with four bolts 5/16-18UNC, 2.36 long or M8x60 - 8.8 DIN 912. Tightening torque 265±221 lb-in [2,5^{+0,5} daNm].

SWITCH VALVES

SPECIFICATION DATA

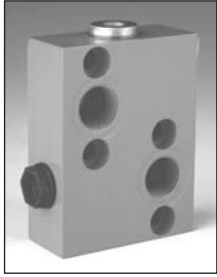

Parameters	Type	
	KPWR	KPWS
Flow Rate , GPM [lpm]	15.85	[60]
Rated Pressure , PSI [bar]	3625	[250]
Weight , lb	1.874	1.477
	[kg]	[0,850]

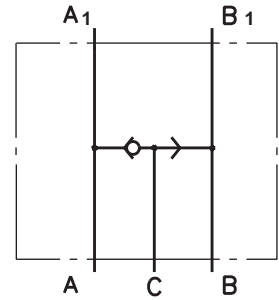

**VALVE FOR MLHP, MLHR, MLHH HYDRAULIC MOTORS
KPWR**

**VALVE FOR MLHS HYDRAULIC MOTORS
KPWS**

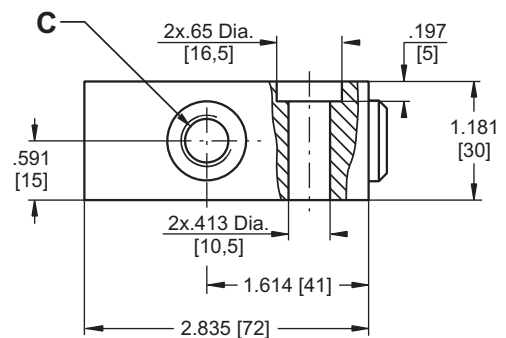
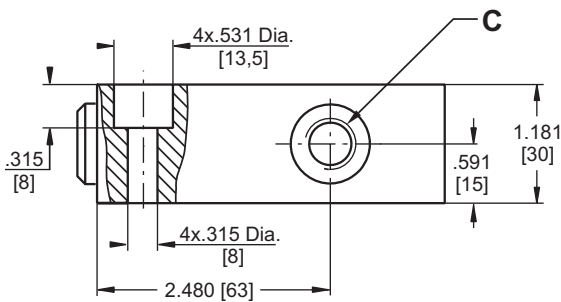
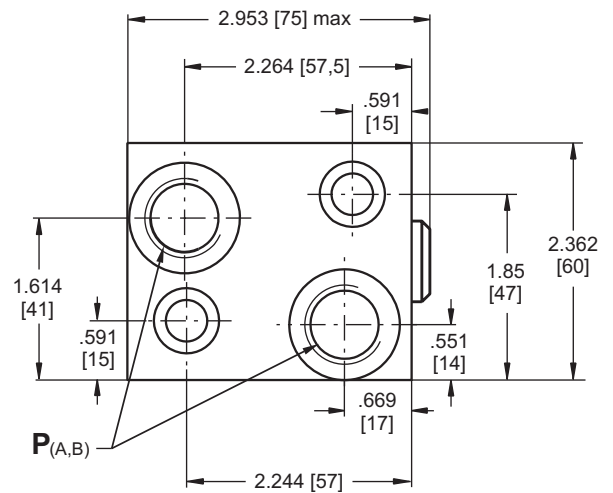
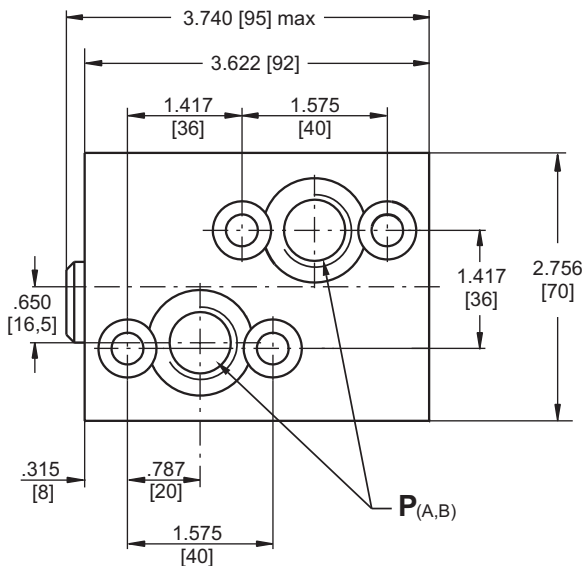

	Thread Ports - P _(A,B)	Thread Port - C
-	G1/2 .67 [17] depth	G1/4 .55 [14] depth
M	M22x1,5 .67 [17] depth	M14x1,5 .55 [14] depth
A	7/8 - 14 UNF O-ring .67 [17] depth	7/16 - 20 UNF O-ring .50 [12,7] depth

Note : **KPWR** Blocks are installed directly on MLHP, MLHR and MLHH Motors with four screws 5/16-18UNC, 1.25 long ANSI B 18.3 or M8x35 - 8.8 DIN 912. Tightening torque 168±150 lb-in [1,7^{+0,2} daNm].
KPWS Blocks are installed directly on MLHS Motors with two screws 3/8-16UNC, 1.25 long ANSI B 18.3 or M10x35 - 8.8 DIN 912. Tightening torque 336±310 lb-in [3,5^{+0,3} daNm].

SWITCH VALVE (continued)

SPECIFICATION DATA

Parameters	Type	
	KPWT	KPWV
Flow Rate , GPM [lpm]	26.4 [100]	52.8 [200]
Rated Pressure , PSI [bar]	3625	[250]
Weight , lb	3.968	6.945
	[1,800]	[3,150]

**VALVE FOR MLHT HYDRAULIC MOTORS
KPWT**

**VALVE FOR MLHV HYDRAULIC MOTORS
KPWV**

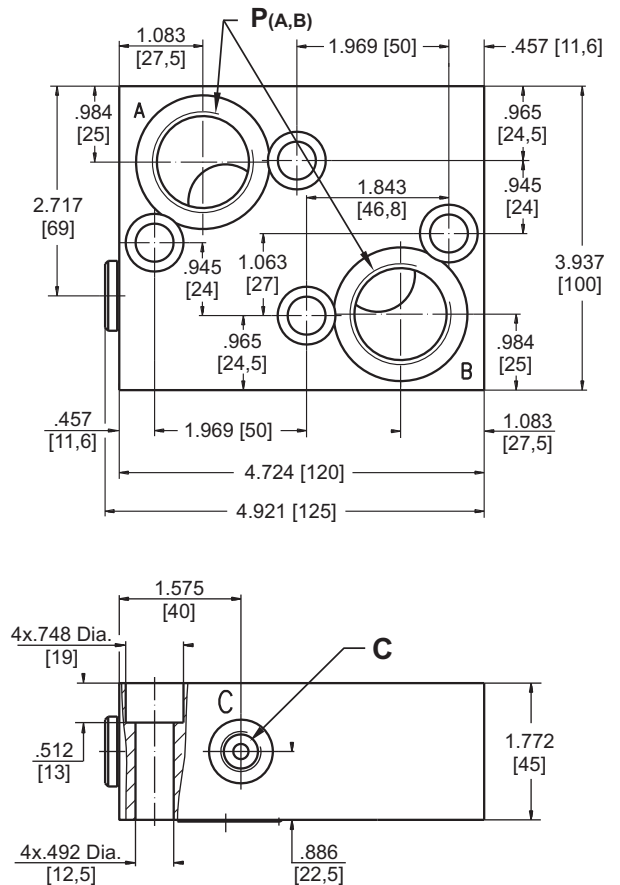
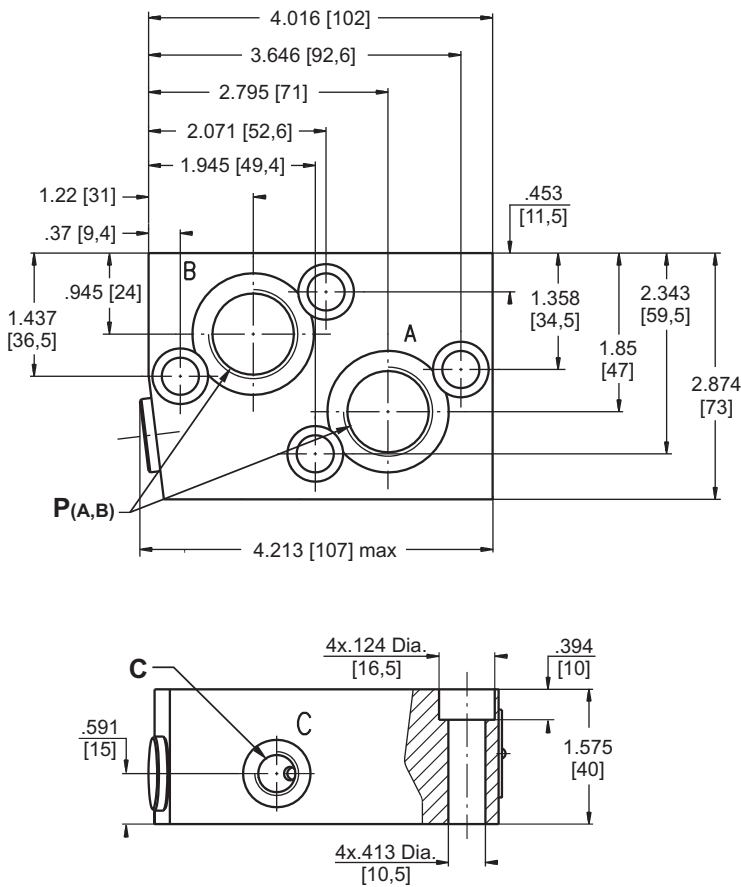

	Thread Ports - P _(A,B)	Thread Port - C
-	G3/4 .67 [17] depth	G1/4 .55 [14] depth
M	M27x2 .67 [17] depth	M14x1,5 .55 [14] depth
A	1 1/16-12 UN O-ring .67 [17] depth	7/16 - 20 UNF O-ring .50 [12,7] depth



	Thread Ports - P _(A,B)	Thread Port - C
-	G 1 .79 [20] depth	G1/4 .55 [14] depth
M	M33x2 .79 [20] depth	M14x1,5 .55 [14] depth
A	1 5/16 - 12 UN O-ring .79 [20] depth	7/16 - 20 UNF O-ring .50 [12,7] depth

Note : KPWT Blocks are installed directly on MLHT Motors with four screws M10x40 - 8.8 DIN 912. Tightening torque 336±310 lb-in [3,5^{+0,3} daNm].
 KPWV Blocks are installed directly on MLHV Motors with four screws M12x45 - 8.8 DIN 912. Tightening torque 620±575 lb-in [6,5^{+0,5} daNm].

CROSSOVER RELIEF VALVES

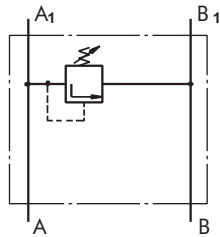

Single Crossover Relief Valve type KPE ...

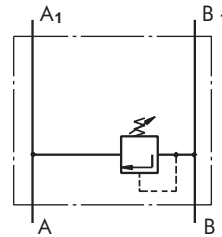

Single Crossover Relief Valve type KPE ...

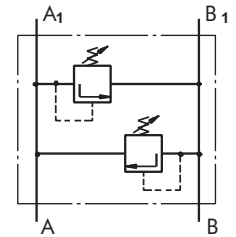

Dual Crossover Relief Valve type KPD ...

SPECIFICATION DATA

Parameters	Type			
	KPER	KPDR	KPES	KPDS
Flow Rate , GPM [lpm]	15.85 [60]			
Pressure Range* , PSI [bar]	435÷1450; [30 ÷ 100];	725÷3050; [50 ÷ 210];	1160÷4350 [80 ÷ 300]	
Weight , lb [kg]	3.42 [1,55]		3.31 [1,50]	

*Pressure Settings are at flow rate of 1.32 GPM [5 lpm] and viscosity 150 SUS [32 mm²/s] (122° F [50 °C]).

Rated Pressure

- A → 1450 PSI [100 bar]
- B → 3050 PSI [210 bar]
- C → 3625 PSI [250 bar]

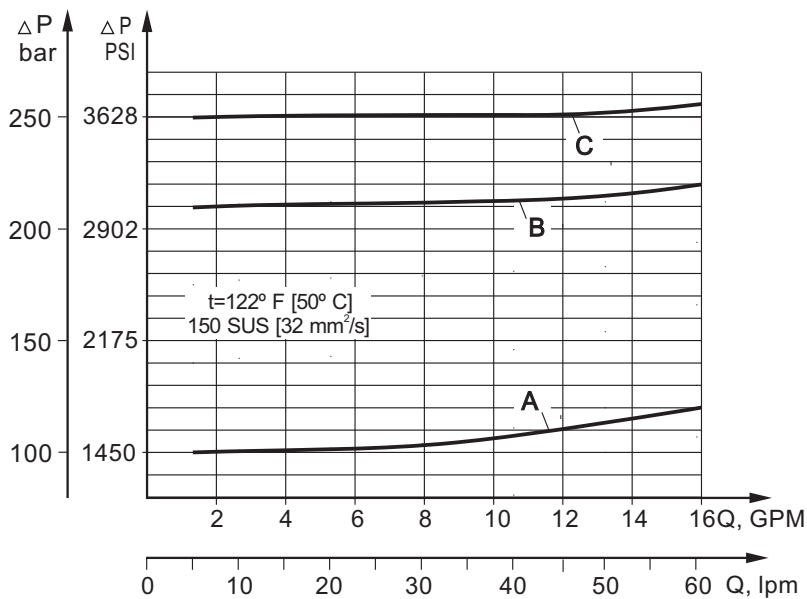

**VALVES FOR MLHP, MLHR, MLHH
HYDRAULIC MOTORS**

DUAL VALVE KPDR

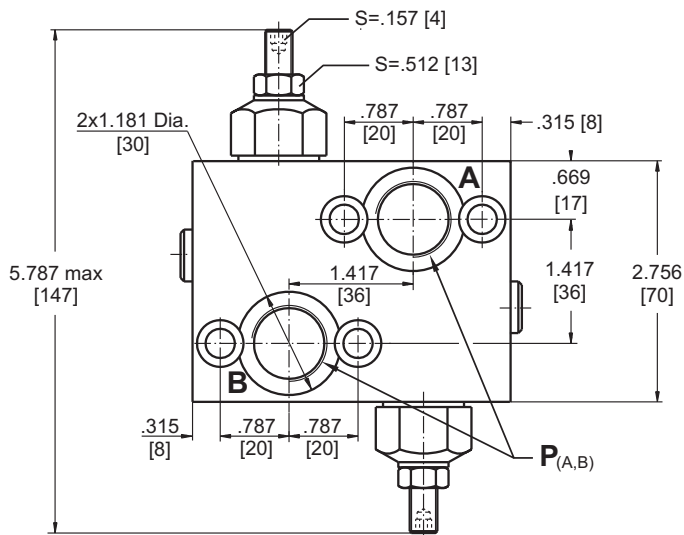

**VALVES FOR MLHS
HYDRAULIC MOTORS**

DUAL VALVE KPDS

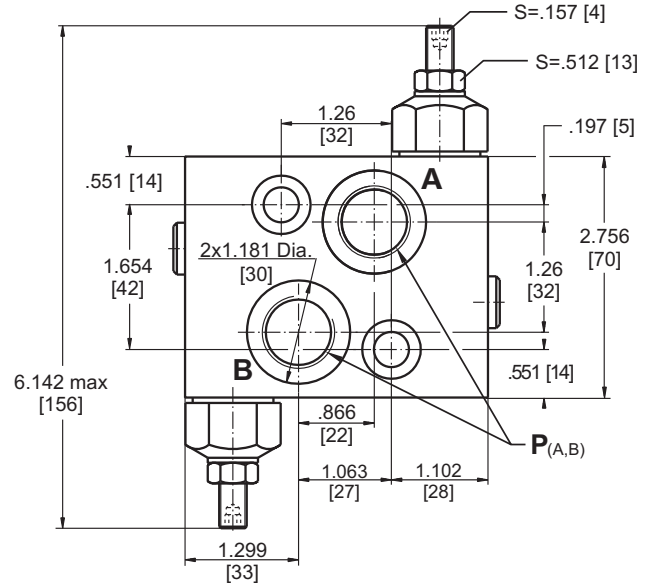

SINGLE VALVE KPER

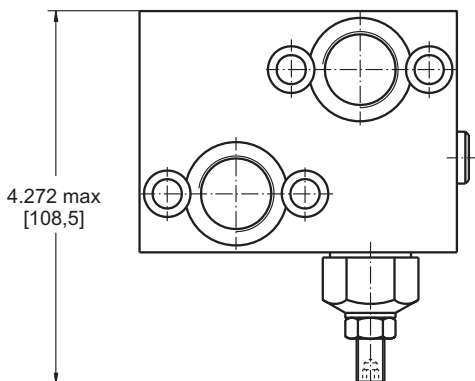

SINGLE VALVE KPES

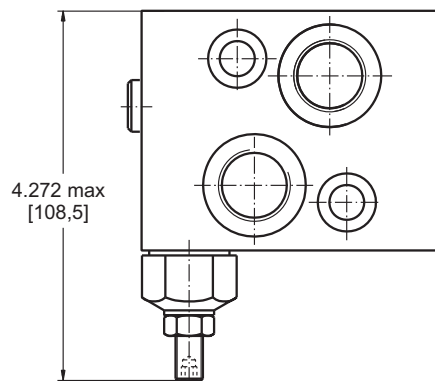

	Thread Ports - P (A,B)
-	G1/2 .79 [20] depth
M	M22x1,5 .79 [20] depth
A	7/8 - 14 UNF O-ring .79 [20] depth



Note : KPER and KPDR Blocks are installed directly on MLHP, MLHR and MLHH Motors with four screws M8x35 - 8.8 DIN 912 or 5/16-18 UNC, 1.5 long ANSI B 18.3 . Tightening torque 177±221 lb-in [2,0^{+0,5} daNm].
KPDS and **KPES** Blocks are installed directly on MLHS Motors with two screws M10x35 - 8.8 DIN 912 or 3/8-16 UNC, 1.5 long ANSI B 18.3 . Tightening torque 310 lb-in [3,5 daNm].

VALVES FOR MLHT HYDRAULIC MOTORS

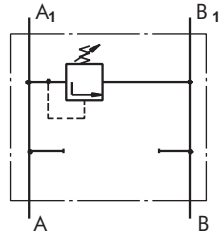

Single Crossover Relief Valve type KPEAT ...

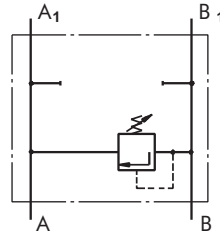

Single Crossover Relief Valve type KPEBT ...

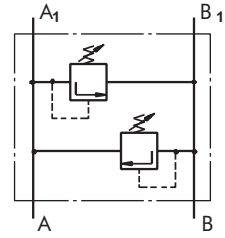

Dual Crossover Relief Valve type KPDT ...

SPECIFICATION DATA

Parameters	Type	
	KPE...T	KPDT
Flow Rate , GPM [lpm]	32 [120]	
Pressure Range* , PSI [bar]	1160÷3050 [80÷210]	
Weight , lb [kg]	11.24 [5,10]	12.21 [5,54]

*Pressure Settings are at flow rate of 1.32 GPM [5 lpm] and viscosity 150 SUS [32 mm²/s] (122° F [50 °C]).

Rated Pressure

- A → 725 PSI [50 bar]
- B → 1450 PSI [100 bar]
- C → 2175 PSI [150 bar]
- D → 3045 PSI [210 bar]

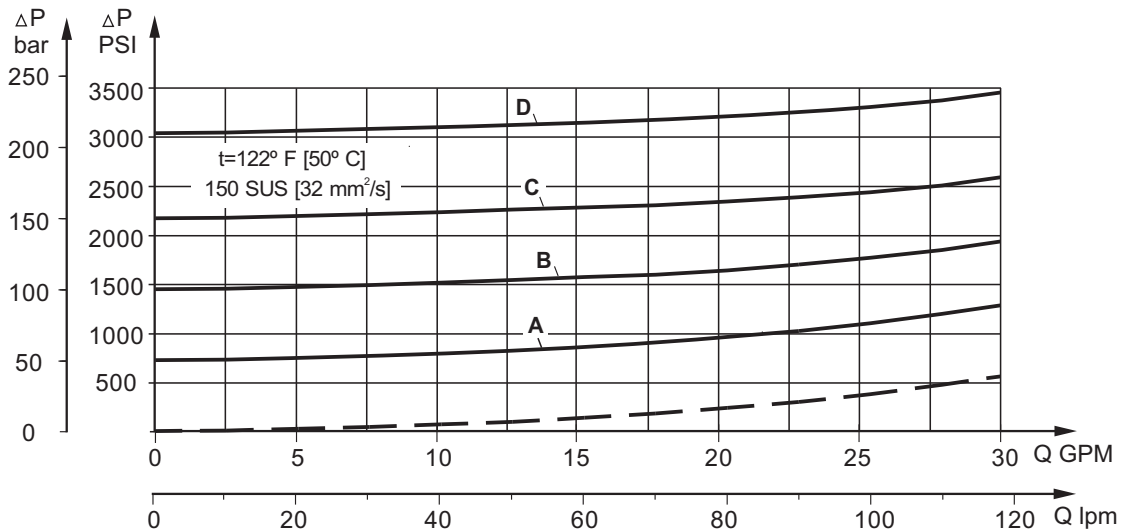

DUAL VALVE KPDT...

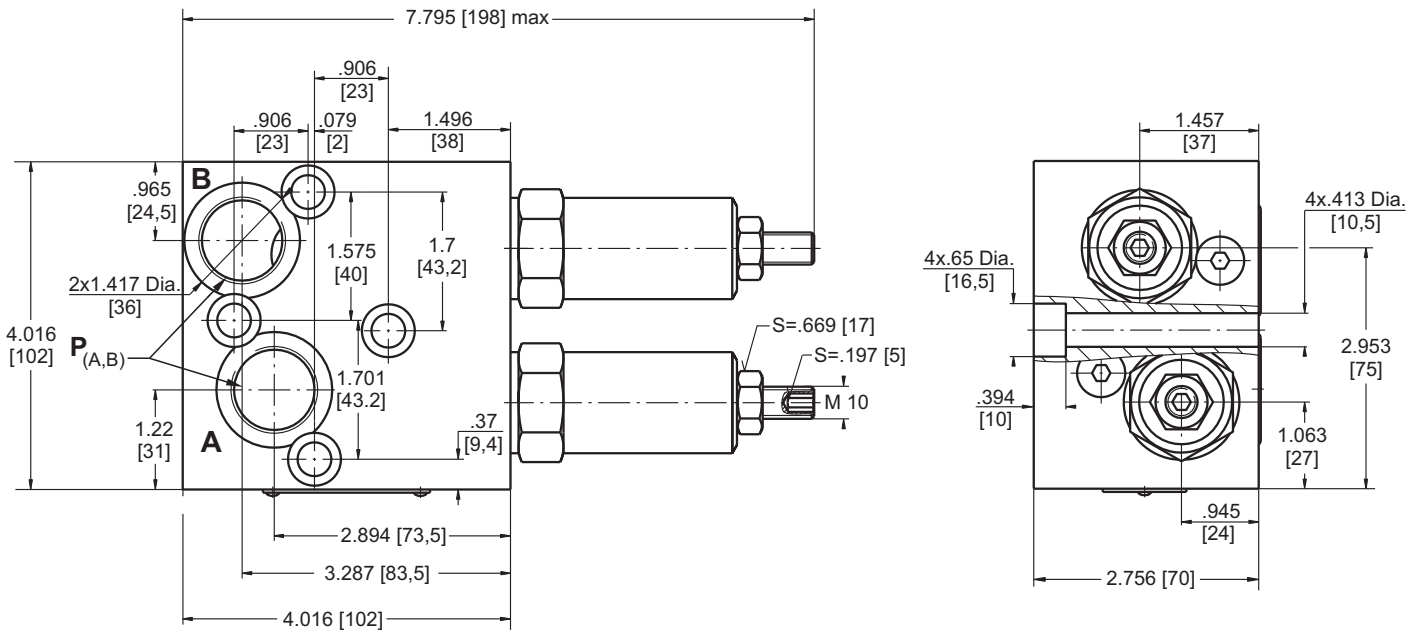

SINGLE VALVE KPEAT...

SINGLE VALVE KPEBT...

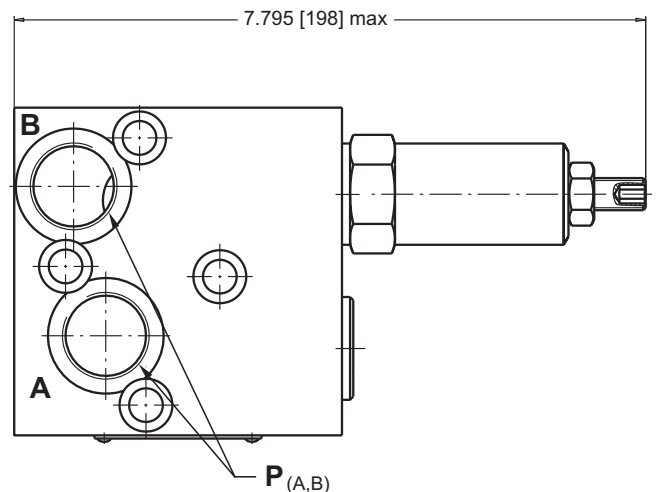
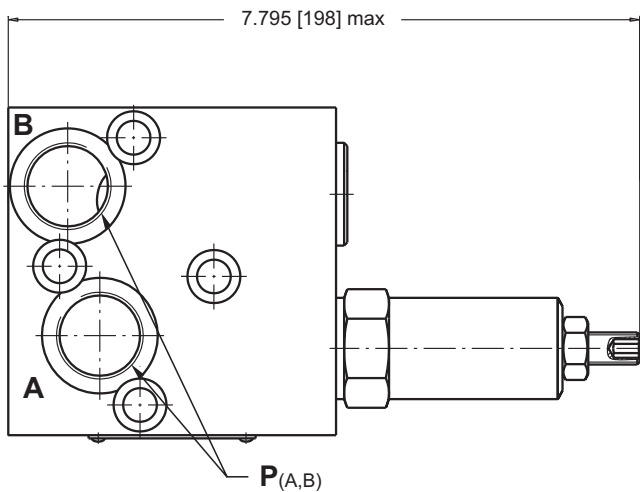

Thread Ports - P _(A,B)	
-	G3/4 .79 [20] depth
M	M27x2 .79 [20] depth
A	1 ¹ / ₁₆ -12 UN O-ring .79 [20] depth



Note : KPDT and KPE...T Blocks are installed directly on MT Motors with four screws M10x70 - 8.8 DIN 912. Tightening torque 310 lb-in [3,5 daNm].

VALVES FOR MLHV HYDRAULIC MOTORS

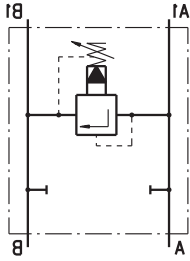

Single Crossover Relief Valve type KPEAV ...

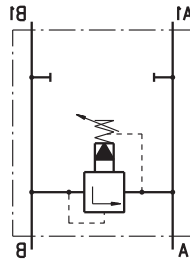

Single Crossover Relief Valve type KPEBV ...

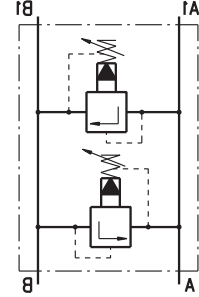

Dual Crossover Relief Valve type KPDRV ...

SPECIFICATION DATA

Parameters	Type		
	KPEAV	KPEBV	KPDRV
Flow Rate , GPM [lpm]	53 [200]		
Pressure Range* , PSI [bar]	145÷1450; 290÷3625 [10÷100]; [20÷250]		
Weight , lb	10.8	15.65	17.64
[kg]	[4,90]	[7,10]	[8,00]

*Pressure Settings are at flow rate of 1.3 GPM [5 lpm] and viscosity 150 SUS [32 mm²/s] (122° F [50 °C]).

Rated Pressure

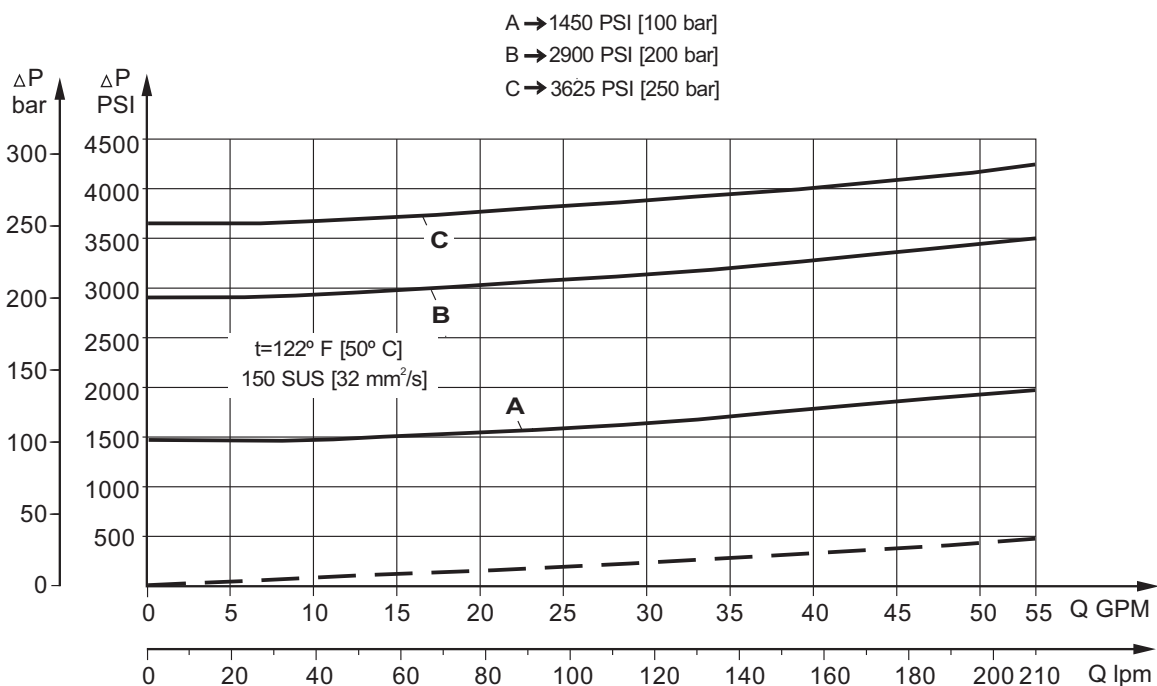

VALVES FOR MLHRW and HW HYDRAULIC MOTORS

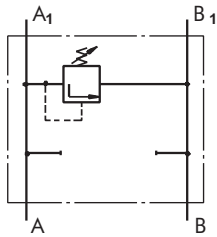

Single Crossover
Relief Valve
type KPEAW ...

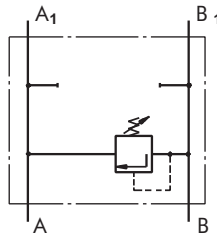

Single Crossover
Relief Valve
type KPEBW ...

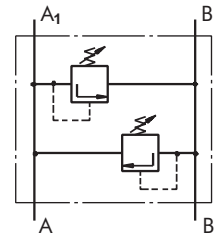

Dual Crossover
Relief Valve
type KPDW ...

SPECIFICATION DATA

Parameters	Type	
	KPE...W	KPDW
Flow Rate , GPM [lpm]	15.85 [60]	
Pressure Range*, PSI [bar]	75÷580; [5 ÷ 40];	435÷1450; [30 ÷ 100]; 1160÷3625 [80 ÷ 250]
Weight , lb [kg]	3.97 [1,80]	6.39 [2,90]

*Pressure Settings are at flow rate of 1.32 GPM [5 lpm]
and viscosity 150 SUS [32 mm²/s] (122° F [50°C]).

Rated Pressure

- A → 1450 PSI [100 bar]
- B → 3050 PSI [210 bar]
- C → 3625 PSI [250 bar]

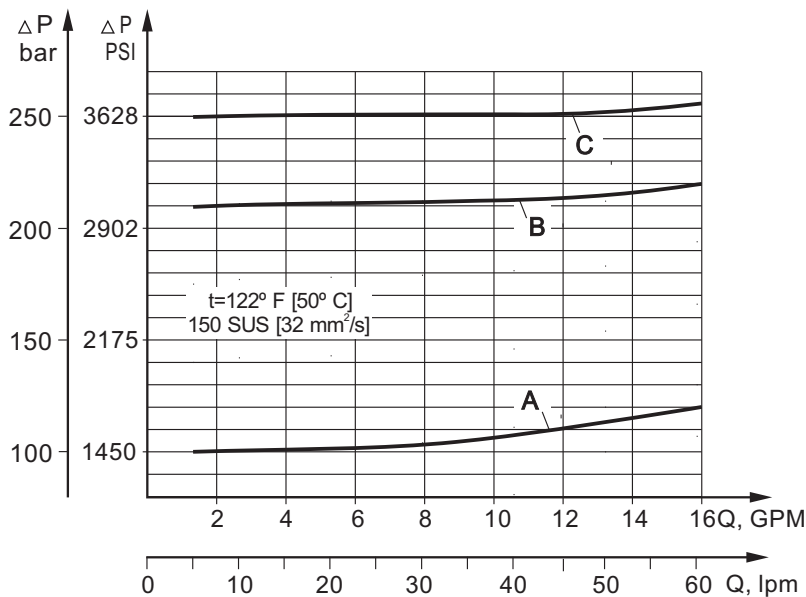

VALVES FOR MLHRW and HW HYDRAULIC MOTORS

DUAL VALVE KPDW...

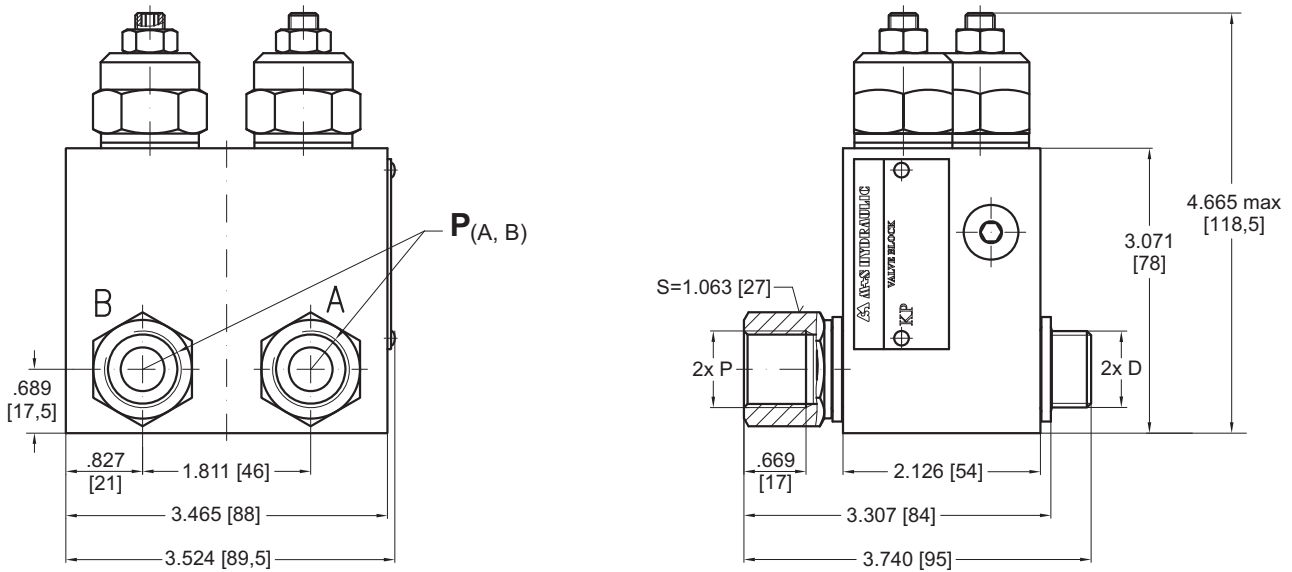

KPDW-...A

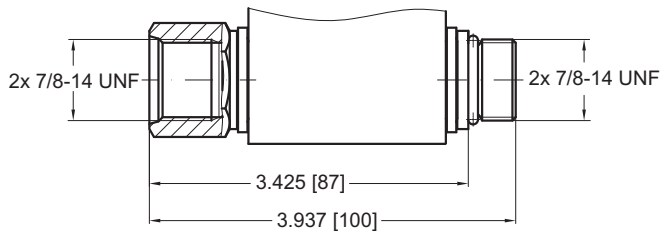

SINGLE VALVE KPEAW...

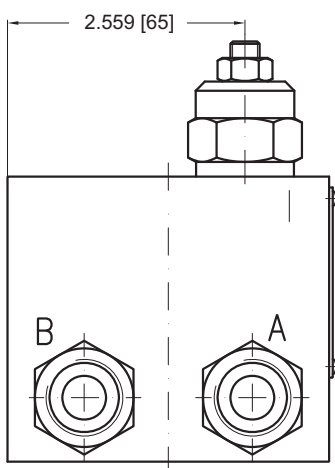

SINGLE VALVE KPEBW...

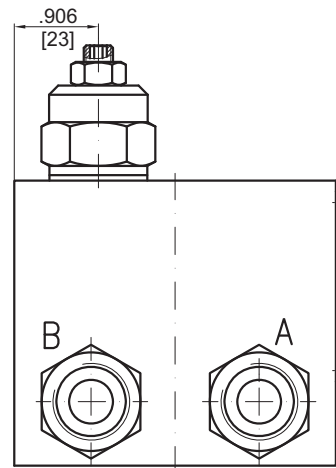

	Thread Ports - P (A,B)	Thread Ports - D
-	G1/2 .63 [16] depth	G1/2 .47 [12] length
M	M22x1,5 .63 [16] depth	M22x1,5 .47 [12] length
A	7/8 - 14 UNF O-ring .63 [16] depth	.47 [12] UNF O-ring .51 [13] length

Note : KPDW and KPE..W Blocks assembly to MLHRW or HW motors is done with two screws (thread D) included in the valve set. Tightening torque 710 lb-in [8 daNm].

CROSS PORT RELIEF VALVES

SPECIFICATION DATA

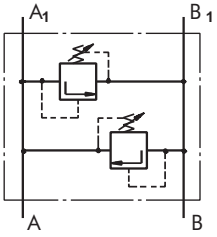

Dual Cross Port Relief Valves type KPDHR... and KPDRK...

Parameters	Type					
	KPDHR			KPDRK		
Flow Rate, GPM [lpm]	15.85 [60]					
Pressure PSI	70÷580	435÷1450	1160÷3625	145÷580	435÷1450	1160÷3625
Range*, [bar]	[5÷40]	[30÷100]	[80÷250]	[10÷40]	[30÷100]	[80÷250]
Weight, lb	5.34			3.53		
[kg]	[2,420]			[1,600]		

*Pressure Settings are at flow rate of 1.3 GPM [5 lpm] and viscosity 150 SUS [32 mm²/s] (122° F [50°C]).

VALVES FOR HP AND HR HYDRAULIC MOTORS

DUAL VALVE KPDHR

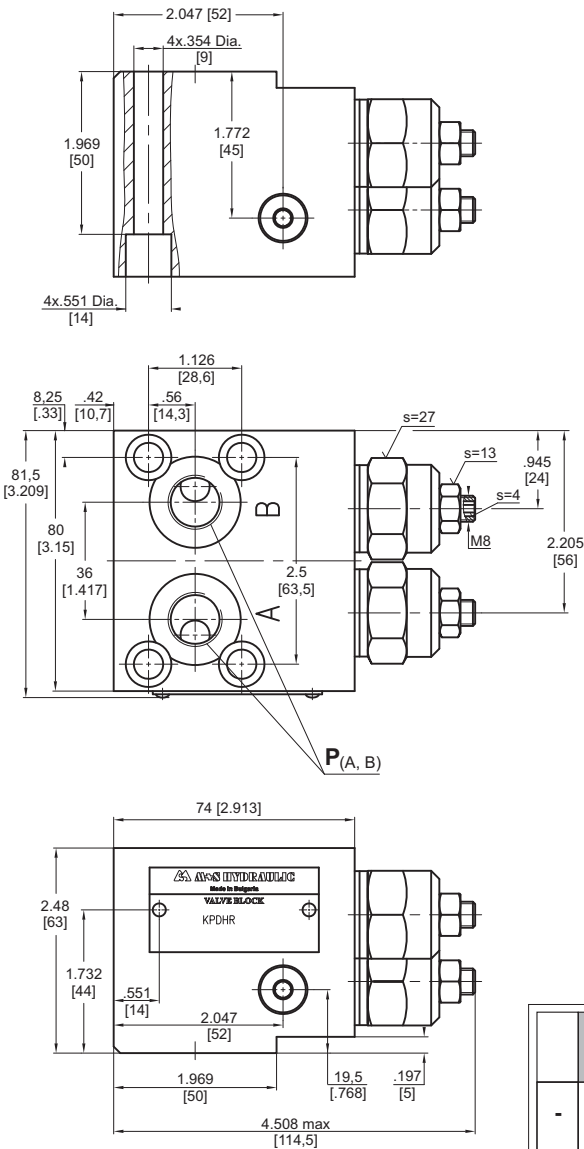

	Thread Ports - P _(A,B)
-	G3/8
M	M18x1,5
A	3/4-16 UNF O-ring

VALVES FOR RK HYDRAULIC MOTORS

DUAL VALVE KPDRK

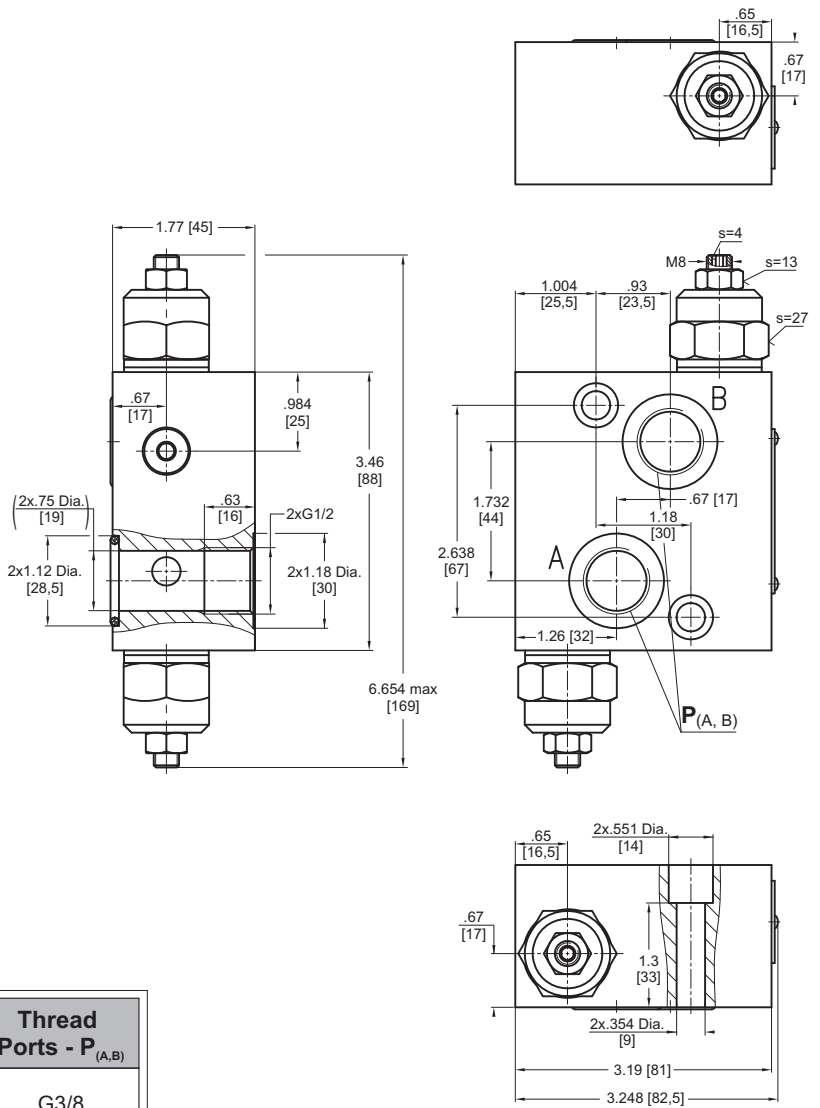

	Thread Ports - P _(A,B)
-	G1/2



ORDER CODE - OVERCENTER VALVES WITH BRAKE CONTROL

1 2 3 4 5 6 7
K P B [] - [] / [] / [] [] [] [] []

Pos.1 - Housing Type

- R** - Valve block for MP, MR and MH Motors
- S** - Valve block for MS Motors
- W** - Valve block for RW and HW Motors
- T** - Valve block for MT Motors
- V** - Valve block for MV Motors
- HR** - Valve block for HP and HR Motors

Pos.2 - Pressure Range, PSI [bar]

- 250** - 1015÷3625 [70÷250], Std Setting 250 bar@5 lpm

Pos.3 - Pilot Ratio

- 1** - 4,25:1

Pos.4 - Number of Valves

- D** - Two Valves - Dual
- E** - One Valve - Single (for R and S only)
- AE** - One Valve on line A - Single (for T, V and W only)
- BE** - One Valve on line B - Single (for T, V and W only)

Pos.5 - Threaded Ports

- omit - BSPP thread - ISO 228
- M** - Metric thread - ISO 262
- A** - Unified inch screw threads ANSI B 1.1 - 1982

Pos.6 - Option [Paint]**

- omit - no Paint
- P** - Painted
- PC** - Corrosion Protected Paint

Pos.7 - Design Series

- omit - Factory specified

Notes: * Color at customer's request.

ORDER CODE - SWITCH VALVES

1 2 3 4
K P W [] [] [] []

Pos.1 - Housing Type

- R** - Valve block for MP, MR and MH Motors
- S** - Valve block for MS Motors
- T** - Valve block for MT Motors
- V** - Valve block for MV Motors

Pos.2 - Threaded Ports

- omit - BSPP thread - ISO 228
- M** - Metric thread - ISO 262
- A** - Unified inch screw threads ANSI B 1.1 - 1982

Pos.3 - Option [Paint]**

- omit - no Paint
- P** - Painted
- PC** - Corrosion Protected Paint

Pos.4 - Design Series

- omit - Factory specified

Notes: * Color at customer's request.

ORDER CODE - CROSSOVER RELIEF VALVE

1 2 3 4 5 6
K P [] [] [] / [] [] [] []

Pos.1 - Number of Valves

- D** - Two Valves - Dual
- E** - One Valve - Single (for R and S only)
- EA** - One Valve on line A - Single (for T, V and W only)
- EB** - One Valve on line B - Single (for T, V and W only)

Pos.2 - Housing Type

- R** - Valve block for MP, MR and MH Motors
- S** - Valve block for MS Motors
- W** - Valve block for RW and HW Motors
- T** - Valve block for MT Motors
- V** - Valve block for MV Motors

Pos.3 - Pressure Range, bar [PSI]

- 100*** - 30÷100 [435÷1450], Std Setting 100 bar@5 lpm
- 210*** - 50÷210 [725÷3050], Std Setting 210 bar@5 lpm
- 300*** - 80÷300 [1160÷4350], Std Setting 250 bar@5 lpm
- 210**** - 80÷210 [1160÷3050], Std Setting 210 bar@5 lpm
- 100***** - 10÷100 [145÷1450], Std Setting 100 bar@5 lpm
- 250***** - 20÷250 [290÷3625], Std Setting 250 bar@5 lpm

Pos.4 - Threaded Ports

- omit - BSPP thread - ISO 228
- M** - Metric thread - ISO 262
- A** - Unified inch screw threads ANSI B 1.1 - 1982

Pos.5 - Option [Paint]****

- omit - no Paint
- P** - Painted
- PC** - Corrosion Protected Paint

Pos.6 - Design Series

- omit - Factory specified

Notes: * Useful for types R and S only.

** Useful for types T only.

*** Useful for types V only.

**** Color at customer's request.

The Valve Blocks are mangano phosphatized as standard.

ORDER CODE - CROSS PORT RELIEF VALVE

	1	2	3	4	5	6
K P				/		

Pos.1 - Number of Valves

D - Two Valves - Dual

Pos.2 - Housing Type

HR - Valve block for HR Motors

RK - Valve block for RK and GHL Motors

Pos.3 - Pressure Range, PSI [bar]

40 - 145÷ 580 [10÷ 40], Std Setting 100 bar@5 lpm

100 - 435÷1450 [30÷100], Std Setting 100 bar@5 lpm

250 - 1160÷3625 [80÷250], Std Setting 250 bar@5 lpm

Pos.4 - Threaded Ports

omit - BSPP thread - ISO 228

M - Metric thread - ISO 262

A - Unified inch screw threads ANSI B 1.1 - 1982

Pos.5 - Option [Paint]*

omit - no Paint

P - Painted

PC - Corrosion Protected Paint

Pos.6 - Design Series

omit - Factory specified

Notes: * Color at customer's request.

The Valve Blocks are mangano phosphatized as standard.